



## BUKIT

### Botanical name:

*Shorea spp. (about 50 species of the genus Shorea, section Rubroshorea)*

### Trade names:

*Dark red meranti, Lauan red, Philippine mahogany, Alan bunga, Seringawan, Alan, Alan-paya, Red selangan, Meraka, Selangan merah, Alan-batu, Dark red Seraya, Bataan, Pata, Aruas, Kila, Mayapis, Pura tiang, Nemesu, Meranti merah, Meranti bunga*

### Location:

Moist evergreen tropical forests of lower and higher elevations in Southeast Asia (Thailand, Laos, Cambodia, Vietnam, Malaysia, Borneo, Sumatra, Philippines)

### General description of wood:

The colour of the heartwood varies according to origin from brownish pink to red to dark red. The sapwood is grey, grey-pink and darkens to a brownish colour. It is quite common to see distinct streaks of white resin. Texture is medium rough, smooth and uniform. Striped in radial section due to regular alternating twist of fibres. The wood is matt glossy.

NATURAL DURABILITY INDEX						
1	2	3	4	5	6	7
1 = VERY HIGH LIFESPAN				7 = LOW LIFESPAN		

*For the highest probability of obtaining wood with natural durability class 4, wood with an average density of at least 670 kg/m<sup>2</sup> at W=12% is selected*

### Wood properties:

Density (at W = 12 %)	500-560-750 kg/m <sup>3</sup>
light to medium weight wood	
Shrinkage in radial direction	3,9 %
Shrinkage in tangential direction	7,8 %
Total volume shrinkage	12,5 %
Medium shape changes, large difference between tangential and radial shrinkage	
JANKA hardness (at W = 12%, radial direction)	42,2 MPa
<b>Group</b>	<b>MPa</b>
Soft	<40

TECHNICAL INFORMATION

Medium hard	≥40
Hard	≥80
Flexural strength ( <i>perpendicular to the fibres of the tang. and rad.</i> )	87,7 MPa
Compressive strength ( <i>in fibre direction</i> )	48,8 MPa

Terrace boards made of BUKIT wood

DIMENSIONS (mm)	LENGTHS (m)	GRADE	DRYING	VIEW SIDE
18 x 140	1,8 – 4,8 *	A/B	16–18 %	smooth
19 x 90	2,4 – 4,5 *	A/B	16–18 %	fine groove
28 x 145	2,4 – 4,5 *	A/B	16–18 %	rough groove

\*stock lengths are multiples of 30 cm = 1.8 m, 2.1 m, 2.4 m, 2.7 m, 3 m, 3.3 m, 3.6 m, 3.9 m, 4.2 m, 4.5 m



**BUKIT 18 x 140 mm - profile detail**

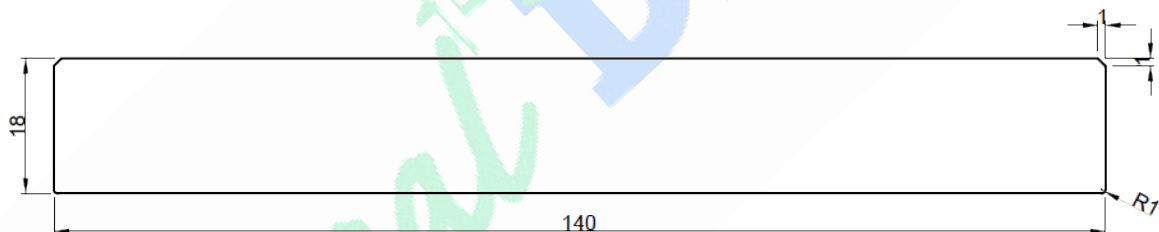

**BUKIT 19 x 90 mm - profile detail**

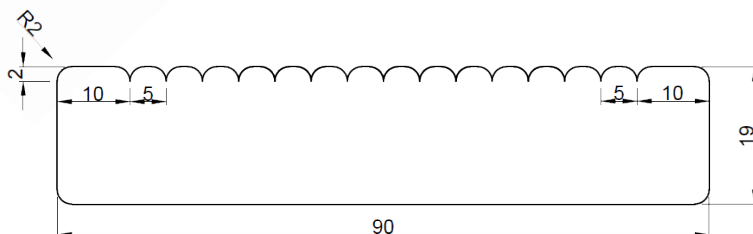

## TECHNICAL INFORMATION



**BUKIT 28 x 145 mm – profile detail**

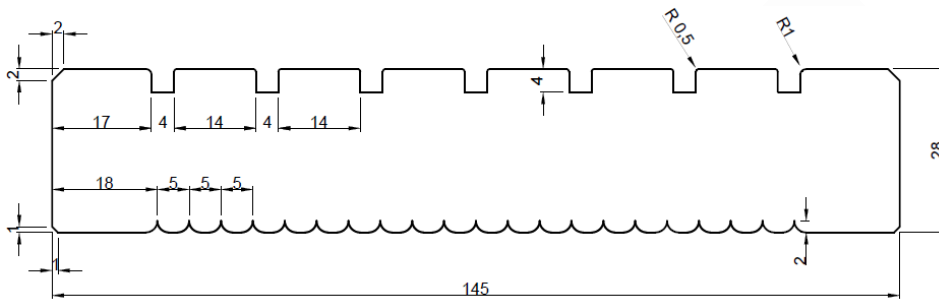

### GRADE

Terrace boards made of BUKIT wood are supplied in A/B grading in a 60:40 ratio. In practice, this means that sixty percent of the material delivered has no defects on the face of the terrace boards at the time of delivery and, in general, the piece can be divided into a maximum of two usable parts during assembly. The remaining forty percent of the supply may show fine surface cracks and end cracks, but these must not run through the entire thickness of the board, but up to a maximum of 1/3 of the length of the decking. An end crack is permitted for a maximum length of one terrace board width. Healthy overgrown knots without restrictions, possibility of local insect holes (*only larval passages Ø 1-2 mm, insects did not survive artificial drying and insecticidal treatment before transport.*) Permitted occurrence of pitcherworms

### DRYING

Wood is a hygroscopic material that changes its moisture content according to its surroundings through absorption, in an attempt to reach a state of moisture equilibrium. Terrace boards made of Bukit wood are kiln dried to a moisture content of 16-18%, which minimizes the risk of undesirable shape changes, significantly increases its mechanical properties with greatly improved resistance to bio attack. Shape changes caused by slumping and swelling can never be completely prevented. As a result of the anisotropic nature of slumping and swelling with simultaneous internal stresses in the wood, transverse and longitudinal buckling and the formation of drying cracks can occur.

## VIEW SIDE

Each terrace board profile has a predefined face to which the grading applies. Quality claims using any other side as a view side will not be taken to consideration.

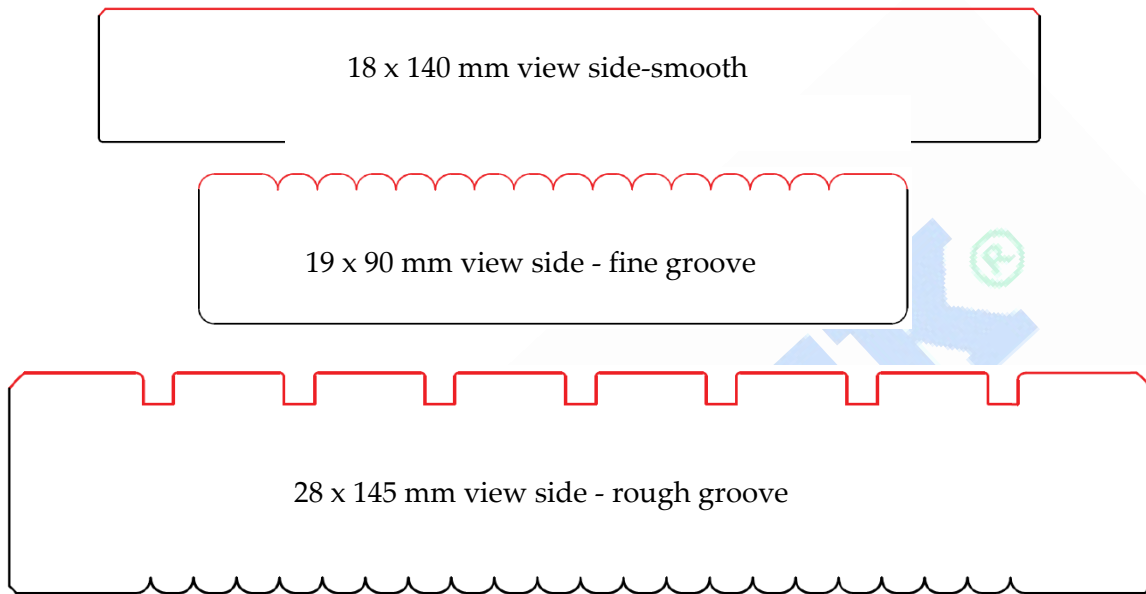

### Spectrum of colours:

Under the trade name Bukit there are about fifty species of the genus Shorea of the Rubroshorea section, which results in a significant colour variance of individual terrace boards from grey shades of white wood to the dark red colour of the core wood. Colour is not subject to grading.

### The greying of the wood:

As soon as the terrace boards are exposed to the weather, they are degraded by the action of so-called inanimate nature. Several interacting influences (water, radiation, flow, temperature changes, smog, emissions, etc.) cause the lignin to decompose by photochemical reactions in the first phase. This decomposition does not cause any observable darkening of the wood under outdoor conditions, because the disturbed lignin is subsequently washed away by rainwater, producing a lighter shade due to the light colour of the unremoved cellulose. In practice, however, the light shade is disturbed by the deposition of dust particles and impurities from the air into the porous structure of the wood surface, or by the co-growth of microscopic fungi, resulting in the well-known greying of the wood..

### Choice of fasteners:

**Choice of fasteners:**

Bukit terrace boards are moderately stable and can be installed with both visible and invisible anchoring systems. Only material that does not cause a chemical reaction with the wood must always be used to prevent deterioration. This involves the use of steel grade at least A4 for visible bolted connections, or composite materials meeting the strength requirements for EURO Tec invisible anchoring.

TERRACE BOARD	STEEL GRADE	DIMENSION OF THE ROLL	INVISIBLE ANCHORING
BUKIT 18 x 140 mm	A4	5 x 50 mm	YES
BUKIT 19 x 90 mm	A4	5 x 50 mm	YES
BUKIT 28 x 145 mm	A4	5 x 70 mm	YES

**Substructure:**

Installation of terrace boards can only be done on a solid wood substructure in one piece in available lengths of 2 - 5 m of the same or higher bio-resistance with a minimum profile of 45 x 70 mm (*exotic wood Jarana, Bangkirai*). Substructures made of laminated and glued together slats of the same or higher bio-resistance wood species can be used exclusively for the construction of covered terraces without permanent weathering. The aluminium profile substructure is shape stable, weatherproof, UV-resistant, insect and mould resistant and suitable for the construction of any terrace, regardless of the type of wood. The minimum axial spacing of the substructure for individual thicknesses of terrace boards is given in the following table.

**Minimum permitted axial spacing:**

TERRACE BOARD	MAXIMUM AXIAL SPACING OF THE UNDERLYING PRISMS
BUKIT 18 x 140 mm	360 mm
BUKIT 19 x 90 mm	380 mm
BUKIT 28 x 145 mm	500 mm

**Board contraction and expansion joints:**

Due to the hygroscopicity and anisotropy of the wood, there can always be a slight deformation of the terrace boards in the longitudinal direction (curvature). These shape changes are not a defect in the material and do not prevent the installation of the terrace boards. To minimize the formation of shape changes, it is necessary to store the material tightly jointed until the time of installation. For easier assembly of curved boards, it is possible to use clamps designed for this purpose. Due to swelling and shrinking of wood due to weathering, it is necessary to leave a minimum of 8 mm of expansion between the individual terrace boards. The dimension of the expansion joint will change throughout the year as the dimensions of the terrace boards change due to weather changes. The main function of the expansion joint is the free movement of the terrace boards without the risk of damage.

**Contains:**

Exotic wood is very rich in extractives and natural pigments. These substances can leach out of the wood and cause colour stains on the surface of the wood and surrounding structures. During installation, care must be taken to ensure rainwater drainage and structural protection.

**BUKIT 28 x 145 mm**

The 28 x 145 mm terrace boards are fitted with a tongue and groove on the transverse side of the conical shape, which allow for length adjustment outside the substructure, as long as the joint does not exceed 1/3 of the axial spacing (*maximum 17 cm overlap*)

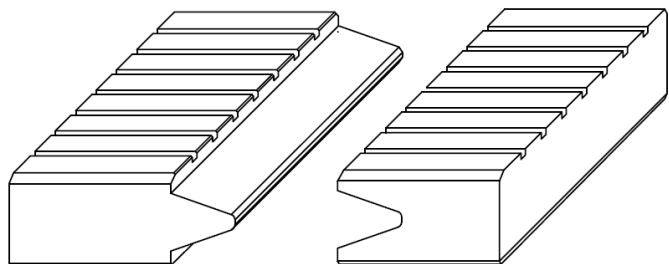
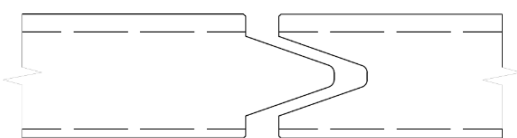



## TECHNICAL INFORMATION

### Surface treatment

To increase protection against biotic and abiotic degradation, a terrace made of Bukit wood should be coated with one of OSMO's pigmented terrace oils (*colourless coating is not recommended*). The application is carried out at the earliest two months after exposure to the weather in order to allow the leaching of the contained substances and the penetration of the paint into the pores of the wood. In order to maintain the best possible hydrophobic properties, it is advisable to carry out a renovation coating at an interval of about six months. To reduce the risk of face cracking, it is recommended that all transverse cuts are coated with OSMO 5735 cutting edge wax



### Remark:

The Technical Data Sheet serves as a supplement to the "Technical and Warranty Conditions of Real DECK"

Please note that our recommendations for the processing of boards for terraces are not binding installation guidelines, but recommendations. Each terrace is characterised by different parameters and the correct installation and use of materials is always the responsibility of the installation company..

Au-Mex I dt., Podebradska 574/40, 198 00 Prague 9 – Vysocany,  
[www.au-mex.com](http://www.au-mex.com), [info@realdeck.cz](mailto:info@realdeck.cz)

